

Fireloch™ Assembly Instructions

Your kit should contain the following items. If you find a part missing, please contact NeoLoch for a replacement.

Kit contents:

- 1 PIC16F57 Microcontroller
- 1 28 Pin Socket
- 13 1 Meg Ohm Resistors
- 1 8 Mhz Resonator
- 1 .1uF Capacitor
- 1 Diode
- 1 6 Pin RA Strip Header
- 1 14 Pin Straight Strip Header
- 1 6 Pin Straight Strip Header
- 1 Printed Circuit Board

When assembling the board you'll notice that some pads are square while the others are round. The square pad is the pin 1 indicator and will aid in the board's assembly.

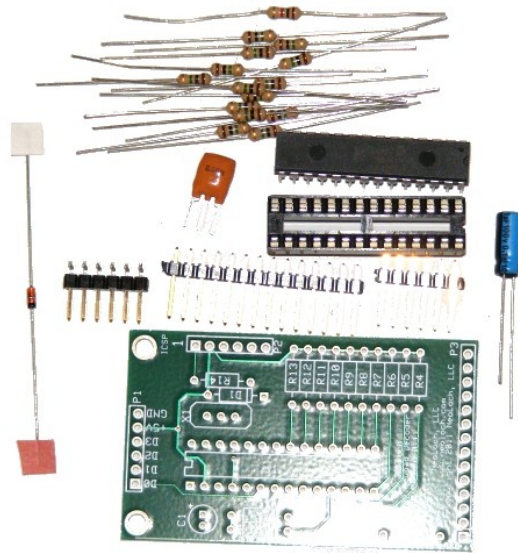

Preliminary

Step One – Solder in the 1 Meg Ohm Resistors (Required)

Assembly of the board will progress from the lowest profile parts to the highest. So we'll begin with installing the 13 1 Meg Ohm resistors.

Solder in all the 1 Meg Ohm resistors in the locations shown (R2 – R14)

The 1 Meg Ohm Resistors have the following color code:

Brown	=	1
Black	=	0
Green	=	00,000
Gold	=	5% Tolerance.

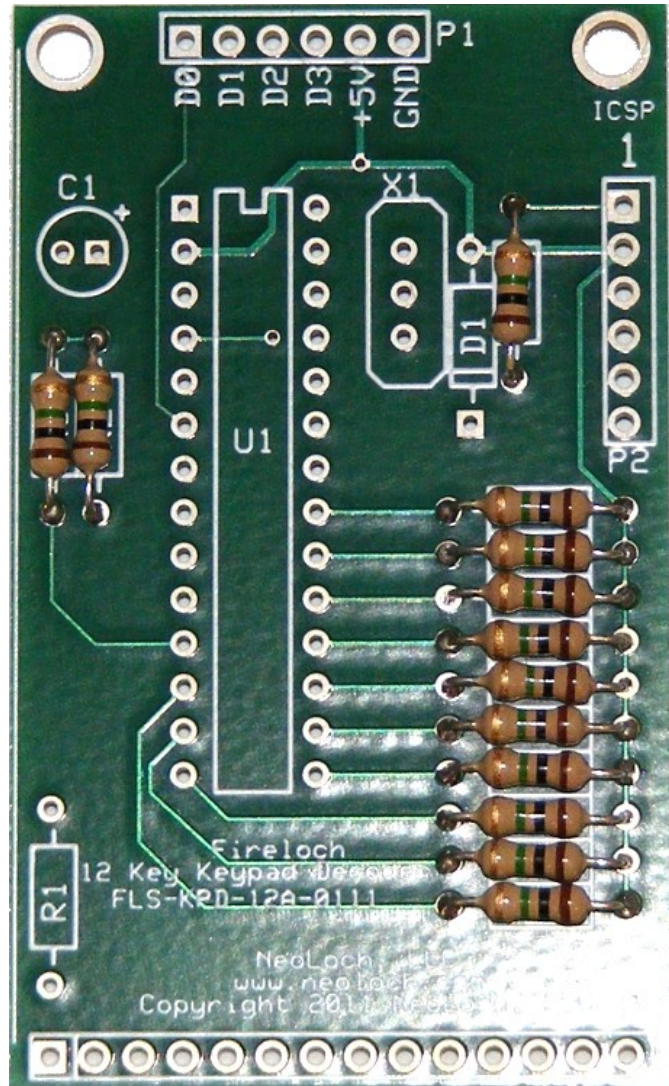

Step Two – 1K Ohm Resistor (Required)

Next, install the 1K Ohm Resistor.

The 1K Ohm Resistor has the following color code:

Brown	=	1
Black	=	0
Red	=	00
Gold	=	5% Tolerance.

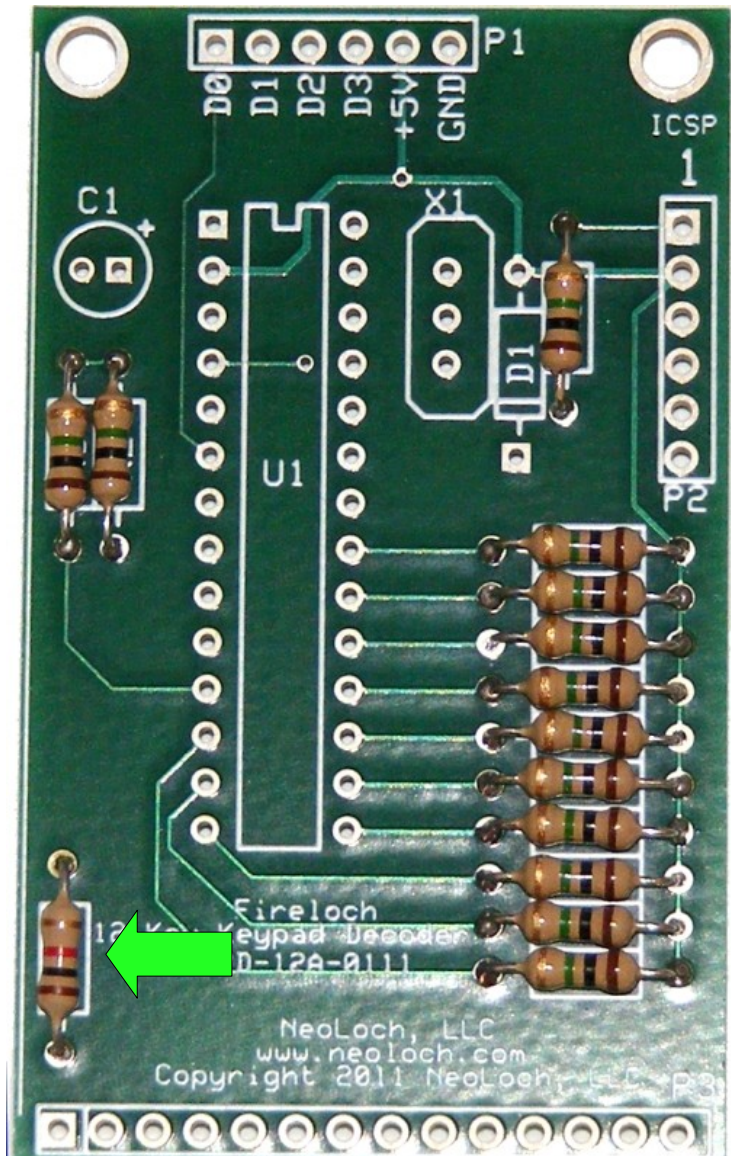

Step Three – Diode (Required)

Next, install the 1K Ohm Resistor.

Be extra careful to install the diode correctly. The colored band needs to point in the same direction as the silkscreen image on the pc board. If you are holding the board as shown in the image, then the black band will be pointing down.

Installing the diode can cause serious damage to the device if you program the PIC using a programmer. The diode is used to prevent programming voltage from harming other components on the PC board.

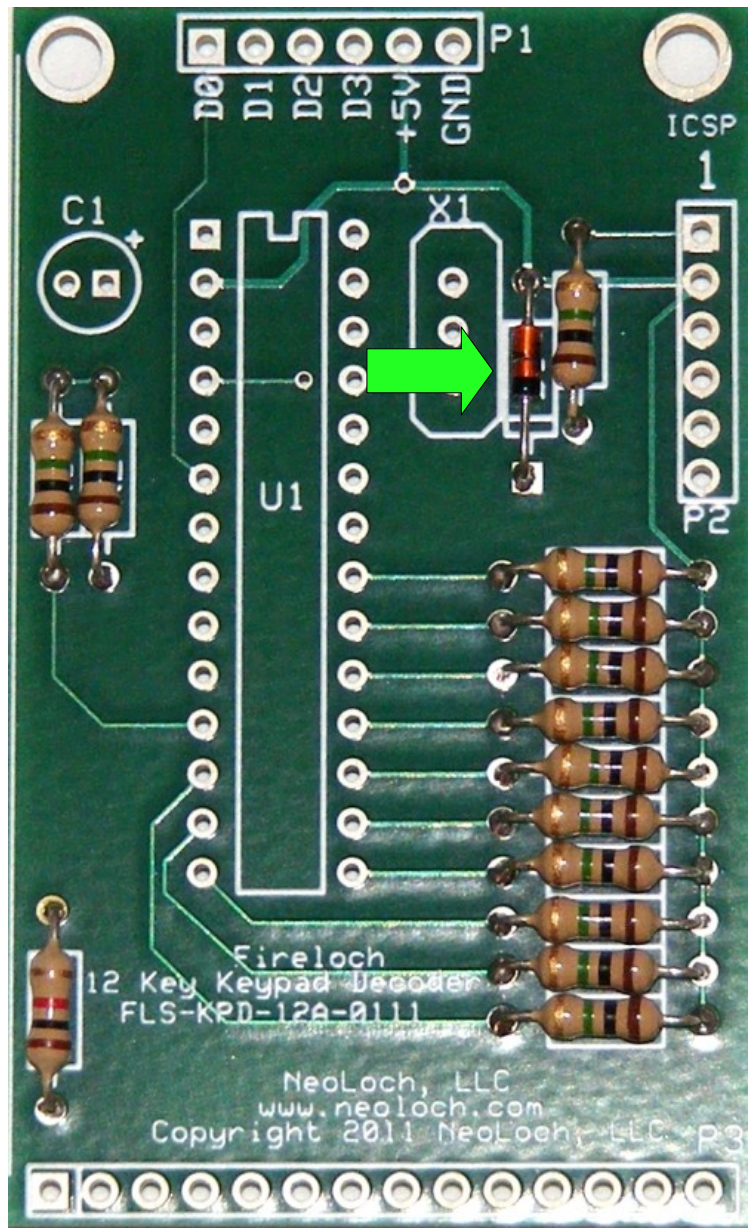

Step Four – 6 Pin R/A Connector (Recommended)

Next, install the R/A 6 Pin connector.

Though this step is not required for the decoder to operate correctly, it is recommended that you install the ICSP header for future use.

With the ICSP header installed, you can write your own code to run on the decoder, which is a great way to explore the decoders functions.

NOTE: To program the PIC16F57 you will need a separate programmer, such as the PICKit™ 2 or PICKit 3.

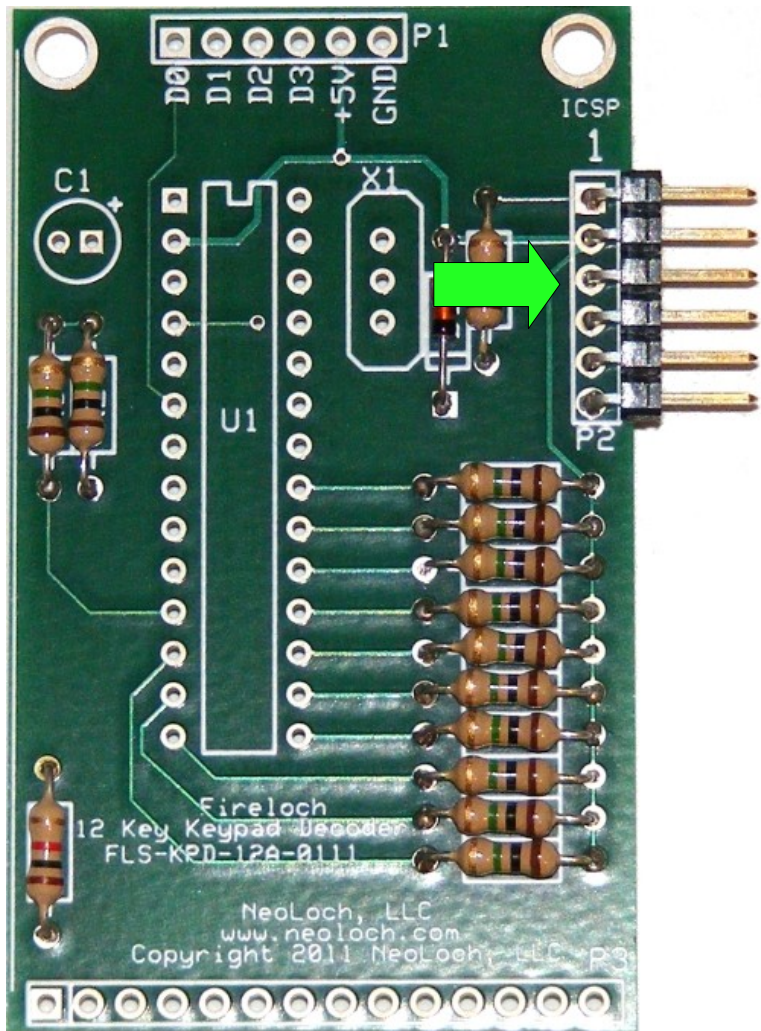

Step Five – 28 Pin Socket (Required)

Now, install the socket.

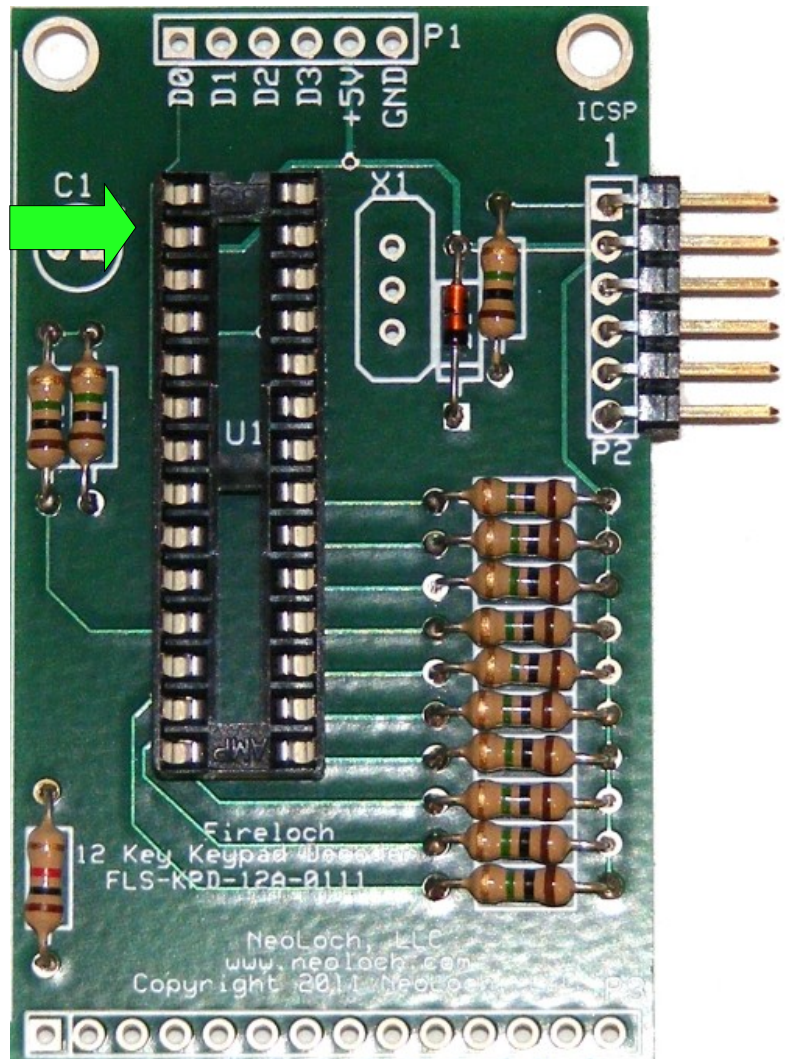

Step Six – Resonator (Required)

Install the 8 Mhz Resonator.
Since orientation of the resonator is not critical it can be inserted in either direction.

NOTE: The PIC16F57 is capable of running up to 20 Mhz. So feel free to replace the resonator with a faster one if desired. However, increasing the clock speed will change the amount of time the default firmware waits for allows for debouncing. Modifying the firmware to accommodate the change in clock frequency is highly recommended.

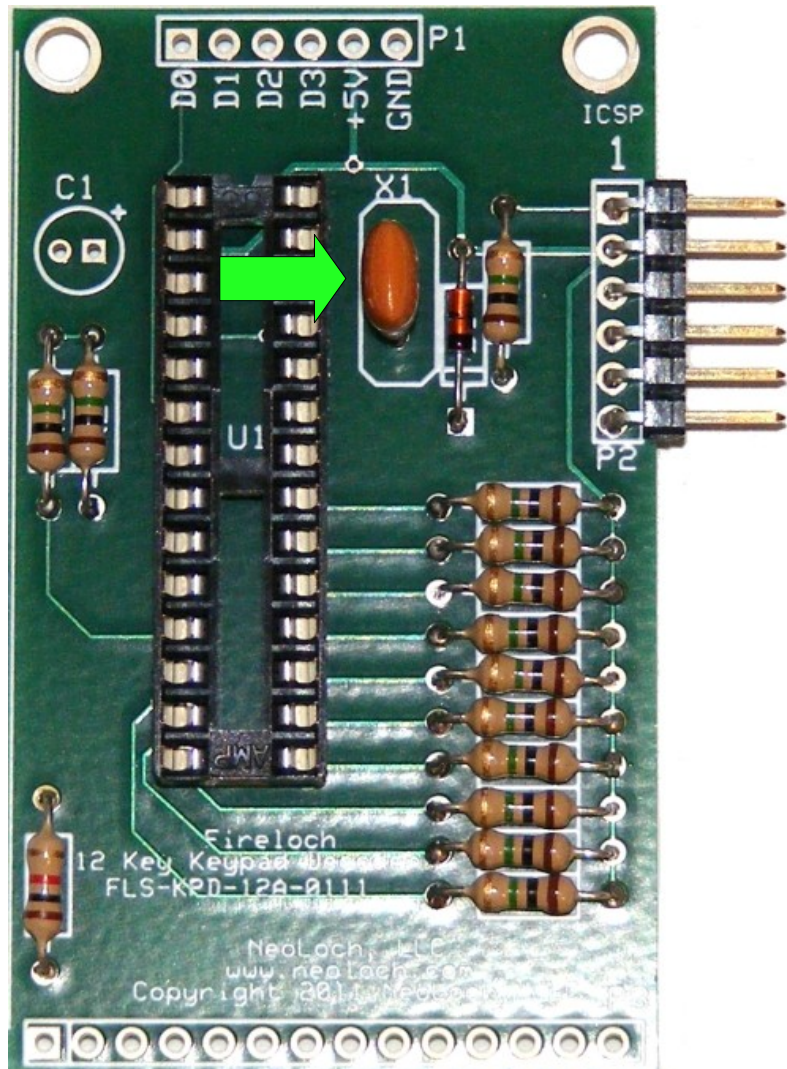

Step Seven – 6 Pin Straight Header (Optional)

If you plan on using your own connector, this step can be skipped.

Now, insert the 6 pin straight header from the bottom of the board so that it is pointing down. This way the board can be inserted into a breadboard or a socket.. This step is optional if you plan on using a different style connector.

Tip: getting the pin headers to lay perfectly flat can be a challenge. One way of insuring a good footing it to solder just one pin and then check to make sure the connector is laying flat. If it's not, hold the board with one hand and apply light pressure to the connector, then use the iron to melt the solder on the single pin. Allow the connector to seat, remove the iron, and allow the solder to cool. You can now proceed to solder the rest of the pins.

Caution: Be careful using the above mentioned seating tactic, the soldering iron is very hot and it's easy to get burned.

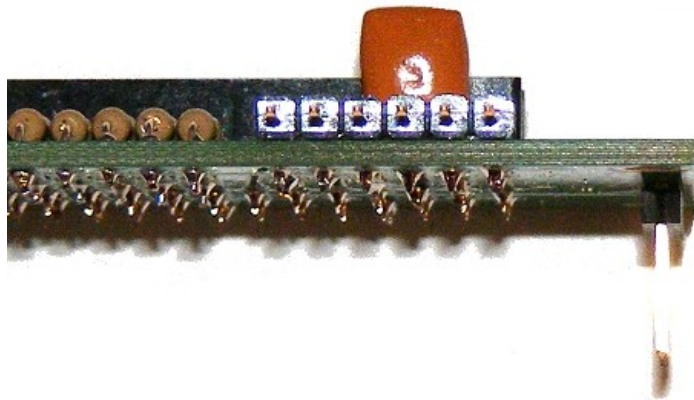
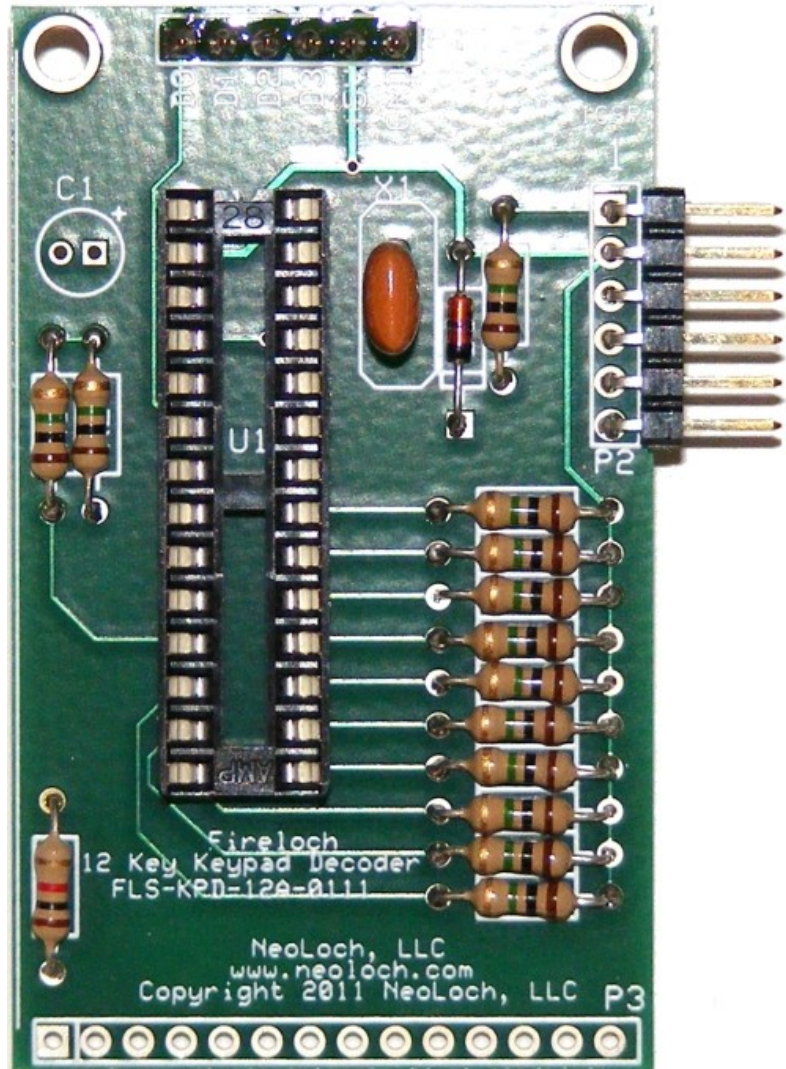

Step Eight – Install The 14 Pin Straight Header (Optional)

If you plan on using your own connector, this step can be skipped.

Now, insert the 14 Pin Strip Header so that the header is pointing up. Turn it over, then solder one pin into place. Now, using the same method as described for the six pin header, adjust the 14 pin header so that it's seated correctly.

Tip: getting the pin headers to lay perfectly flat can be a challenge. One way of insuring a good footing it to solder just one pin and then check to make sure the connector is laying flat. If it's not, hold the board with one hand and apply light pressure to the connector, then use the iron to melt the solder on the single pin. Allow the connector to seat, remove the iron, and allow the solder to cool. You can now proceed to solder the rest of the pins.

Caution: Be careful using the above mentioned seating tactic, the soldering iron is very hot and it's easy to get burned.

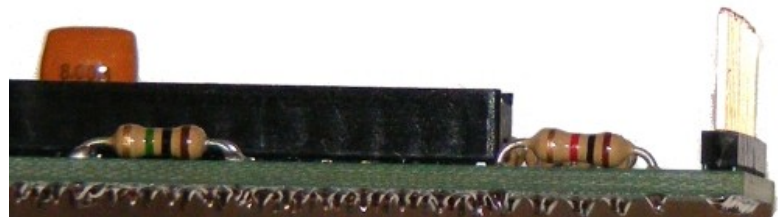
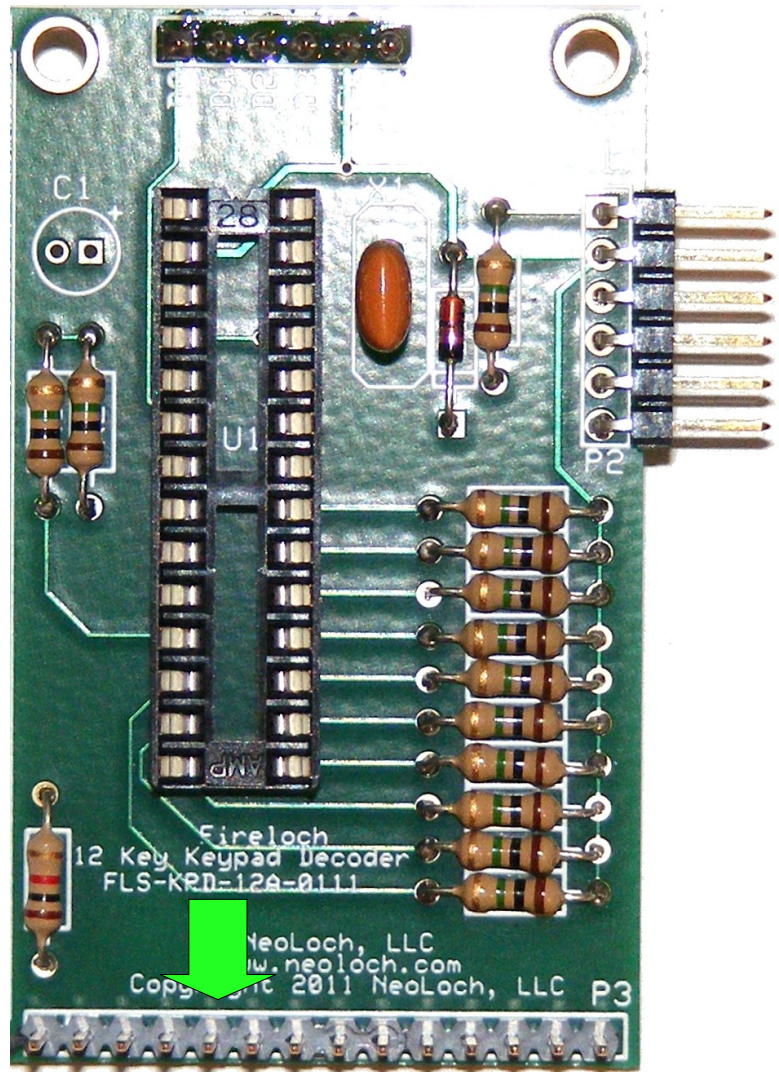

Step Nine – Install The Bypass Capacitor & PIC16F57

Now, we can finish up by installing the bypass capacitor. Be sure to align the capacitor correctly so that the ground pin is going into the ground hole. The positive side of the capacitor is the closest one to the PIC.

After you've done this, install the PIC16F57.

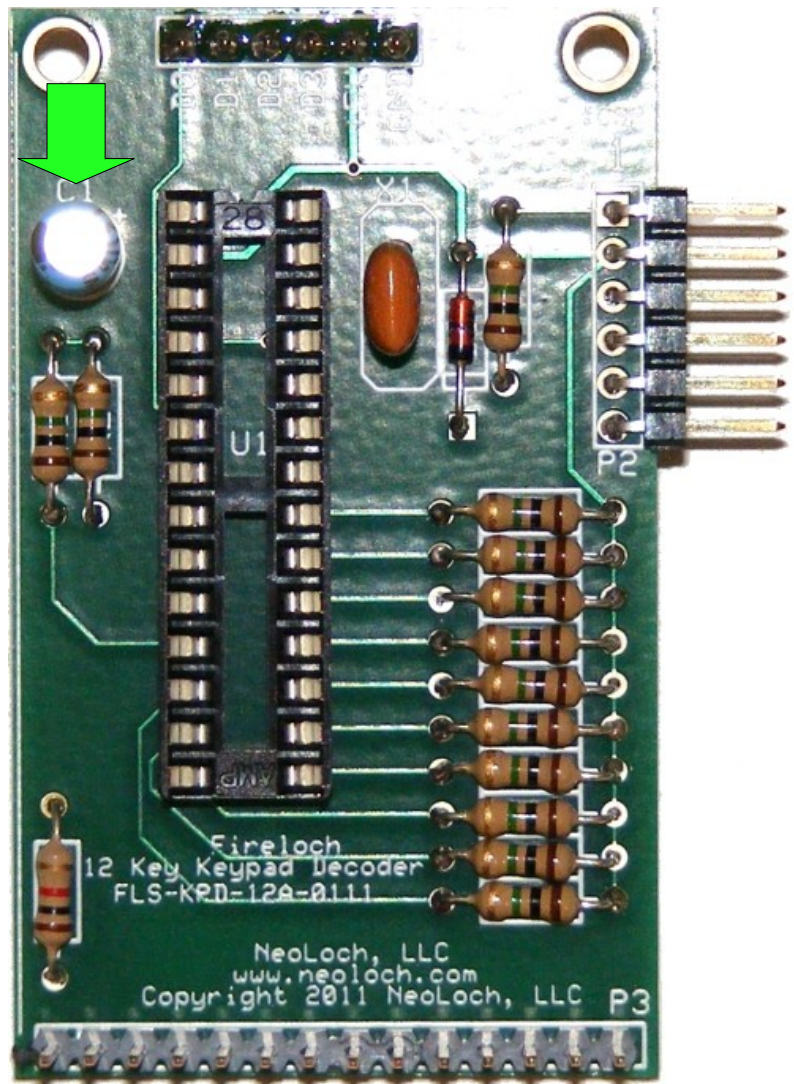

Step Seven – 14 Testing The Unit.

That's it, you're done. The keypad decoder is ready for testing. Just to make sure that nothing major is wrong, it's recommended that you do a continuity test between the power and ground pin. Then, if all is well, use the following sequence to test the decoder.

1. If you haven't done so already, plug the decoder into a breadboard
2. Supply appropriate ground and power (+5V) to the decoder.
3. Setup 4 LEDs with resistors in the 390 Ohm to 470 Ohm range.
4. Keep in mind that D0 is on pin one, the data nibble is reversed (LSB is first with MSB last) so keep that in mind when wiring up the LEDs.
5. If you don't have a keypad integrated with the decoder yet, you can still test the unit by shorting pin 1 of the keypad header with pins 3 – 14.
6. If all goes well, as you touch the wire to pins 3 – 14 or press a key on the keypad, the LEDs will light up.

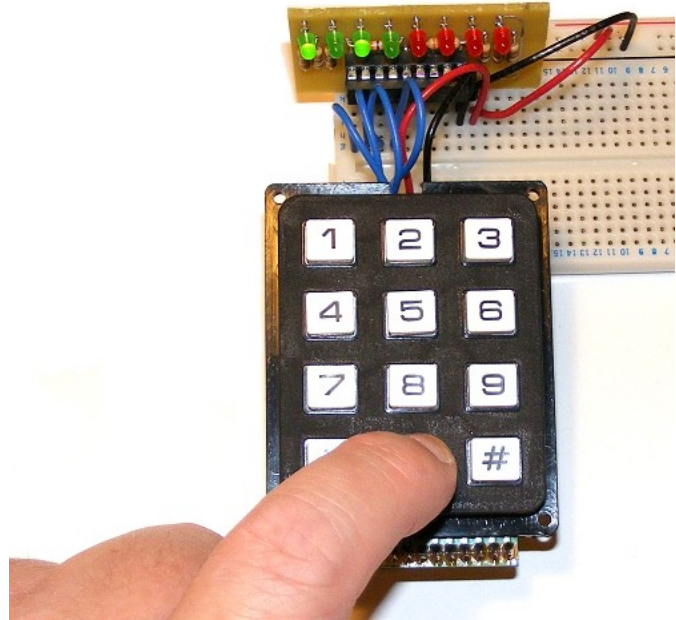

If you don't see the lights light up, then proceed to the troubleshooting section.

The demo code is available in .asm form from the KPD-12A-0111 page on NeoLoch's website and the code is being distributed under the Creative Commons Attribution-NonCommerical 3.0 Unported License. For more information on this license, follow the link below.



all [NeoLoch, LLC](#) code listed on this page is licensed under the [Creative Commons Attribution-](#)

Troubleshooting

If your board doesn't work, try these solutions before contacting NeoLoch for assistance.

1. Check to make sure that the ground and power pin are being supplied correctly. Check for proper voltage supply.
2. Check all the solder joints to make sure nothing was missed. Especially the microcontroller's socket. If even a single pin isn't soldered correctly, it will have an adverse effect on the device's operation.
3. If the board still doesn't work, it's possible your PIC isn't programmed. Though we make every effort to make sure the processor is programmed before leaving, a mistake does happen from time to time. Try programming the PIC with the current firmware available from our website. You can find the current firmware for the board on our website.